

Boom - when carrying reels

High flexibility and efficiency - the boom makes it easy to carry reels in horizontal position.

The boom with a quick shift system can readily be fitted on all Logiflex models with an adjustable carriage. Furthermore the boom can easily be exchanged with one of the many Logitrans fork options and optional extras.

A wide range of optional extras ensures an optimum utilisation of the Logiflex - the same Logiflex can be fitted with crane arm, platform, drum turner and reel rotator.

High quality is ensured through an extended test programme and in cooperation with experts in Health and Safety.



Technical Specifications

The boom can handle horizontal reels.

The boom has a quick shift system and is therefore easy and quick to fit on all Logiflex models with adjustable carriage.

The capacity depends on weight and length of the reel. The load is to be placed equally on the boom length.

The load centre of the reel has to be placed behind the load wheel centre on the legs (safety precaution).

Strong construction ensures a long operating life and low maintenance costs.



Quick shift makes it easy to replace the boom by other optional extras or forks.



The lifting/lowering function of the electric Logiflex models can be operated by remote control (optional extra).



When using a Logiflex without straddle legs, the reel to be handled has to be placed on a pallet.

Product (measured in mm)	LF, ELF, SELF	LFS, ELFS, SELFS	LF, ELF, SELF	LFS, ELFS, SELFS
Run-in lengths	l_x	806	818	1106
Lifting height, boom	h_3	$h_{13} + \text{lifting height (Logiflex)}$		
Lowered height, boom	h_{13}	170 (without load)		
Length of boom	l	800		1150
Diameter of boom	D	40	50	70
Capacity (kg)		330	650	1000



The reel rotator – an ideal alternative when lifting and turning reels.

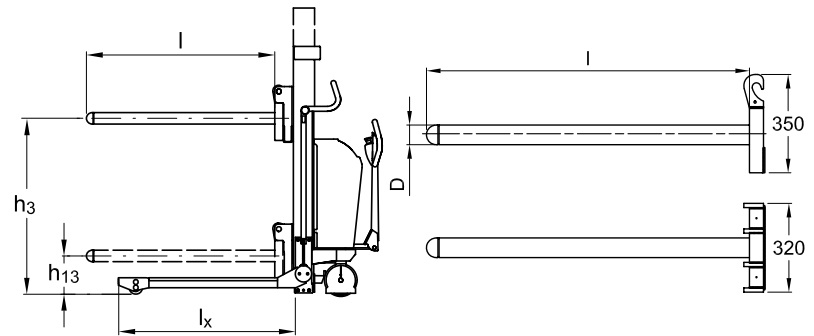

A straddle Logiflex handles reels from a stock to a lorry.



The boom in the packaging industry.



Optional extras, e.g. platform, reel rotator and drum turner.



The boom in a stock area.

We also offer tailor-made solutions.

Please ask for further information or visit our website www.logitrans.com