

Fully powered straddle Logiflex Maxi - makes work easy

High flexibility and efficiency - a fully powered straddle Logiflex Maxi can transport, lift and handle different goods. All types of pallets - also closed pallets - can be handled.

Large range of optional extras ensures an optimum flexibility.

The design puts focus on the safety and ergonomic working conditions of the user - Logiflex Maxi can be adjusted to the individual user, and the ergonomic correct handle ensures the user a relaxed hold.

High quality is ensured through an extended test programme and in cooperation with experts in Health and Safety.



Technical Specifications

Straddle legs make it possible to handle many different pallet types.

High performance with AC technology

- Easy setting of e.g. driving speed, acceleration and deceleration
- Long operating time per charge

Strong construction ensures a long operating life and low maintenance costs.



Available with Rotator and/or optional extras, e.g. drum turner, remote control, level control, built-in charger.



Possible to operate with the handle upright. Central location of all control buttons.



Adjustable forks are available in many different lengths and types.

Product (measured in mm)	SELS MAXI	SELS MAXI	SELS MAXI	SELS MAXI	SELS MAXI	SELS MAXI	SELS MAXI	SELS MAXI	SELS MAXI
Capacity in kg	1000/1200	1000/1200	1000/1200	1000/1200	1000	1000	1000	1000	1000
Lifting height by wrap-over forks	h ₃ 890/870	1170/1150	1370/1350	1570/1550	1880	2020	2420	2820	3270
Fork length	l 600*, 800*, 1067, 1150, 1520**								
Overall height	h ₁ 1320	1530	1730	1930	2240	1530	1730	1930	2240
Overall width	b ₁ 166 + b ₄								
Fork span min./max.	b ₅ Wrap-over: 350/800, bar: 230/680, chisel: 270/680 (1200 kg models are only available with chisel forks)								
Length without forks	l ₂ 703								
Overall length by 1150 forks	l ₁ 1855								
Overall height	h ₄ Without telescopic mast 2490, 2890, 3290, 3740								
Lowered height, forks	h ₁₃ Chisel: 45, bar: 65, wrap-over: 65								
Load centre	c l/2								
Width between legs: Cap. 1000/1200 kg	b ₄ 850 - 942, 942 - 1124, 1124 - 1306, 1240-1422*** / 850 - 942, 942 - 1124								
Fork width	e Chisel: 120, bar: 100, wrap-over: 163								
Run-in length	l _x 967 by 1150 and 1067 fork length								
Gangway (pallet: 1200 x 800)	A _{st} 2200 - tests show that 1700 mm are enough - depends on width between straddle legs								
Free lift	h ₂ 190								
Turning angle of the wheels	210°								
Driving motor	1,2 kW 24 V speed control electronically variable								
Driving speed with/without load	Below 500 mm lift: 5/6 km/h, over 500 mm lift: 3/4 km/h								
Pump motor	1,2 kW 24 V								
Lifting speed with/without load	Cap. 1000 kg: 0,07/0,12 m/s, cap. 1200 kg: 0,04/0,07 m/s								
Lowering speed with/without load	0,12/0,07 m/s								
Weight in kg (no battery): Cap. 1000/1200 kg	411	430	436	440	448	491	498	507	521

* Maximum lifting height 1570 mm by 600 mm fork length, maximum lifting height 2420 by 800 mm fork length.
 ** Reduced capacity 750 kg. Not available for 1200 kg models.
 *** Width between straddle legs of more than 1306 mm: Max. capacity 800 kg. Fork length of 1520 mm is not recommended.



Optimum safety through transparent and impact-resistant safety screen and reduced driving speed in raised position.

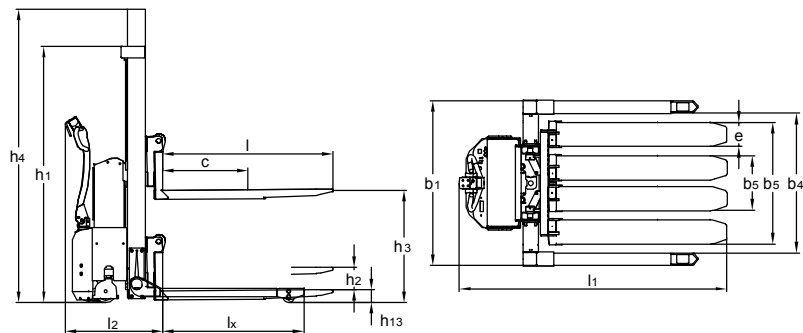

We also offer tailor-made solutions.
 Please ask for further information or visit our website www.logitrans.com