



Premium Electrische Kettingtakel DEH / **Premium** Electric Chain Hoist DEH

Eigenschappen

- » Robuuste constructie.
- » Geschikt voor een breed scala aan industriële toepassingen.
- » Wartel lasthaak met veiligheidsklep.
- » Makkelijk te demonteren voor onderhoudsdoeleinden.
- » Met SIEMENS besturingssysteem.
- » Permanent gesmeerde transmissie, zorgt voor een soepele en stille werking.
- » Geleverd met bedieningsschakelaar, voedingskabel en kettingbak.
- » Voldoet aan de Machinerichtlijn 2006/42/EG. Geleverd met testcertificaat, CE-conformiteitsverklaring en gebruiksaanwijzing.

Features

- » Robust housing.
- » Suitable for a wide range of industrial applications.
- » Swivel load hook with safety latch.
- » Easy to disassemble for maintenance purposes.
- » Control system with SIEMENS relays.
- » Permanently lubricated transmission, ensures smooth and quiet operation.
- » Supplied with control switch, power cable and chain container.
- » Complies with the Machinery Directive 2006/42/EC. Supplied with test certificate, CE declaration of conformity and operating instructions.



DF.0.DEH

Specificaties / Specifications							
Artikel nummer	Capaciteit	Hijssnelheid	Hijsketting	Parten	Energie verbruik	Netto gewicht	Extra gewicht
Article code	Capacity	Lifting speed	Load chain	Chains falls	Power output	Net weight	Extra weight
	ton	m/min	Øxmm		kW	kg	kg/m
DF.0.DEH.002503	0.25	8/2	4 x 12	1	0.4/0.1	22	0.4
DF.0.DEH.00503	0.5	8/2	5 x 15	1	0.72/0.18	33	0.7
DF.0.DEH.01003	1	8/2	7.1 x 21	1	1.6/0.4	53	1.1
DF.0.DEH.02003	2	4/1	7.1 x 21	2	1.6/0.4	58	2.2

Specificaties / Specifications	
Voltage / Operating voltage	400V / 50-60Hz / 3Ph (440V op aanvraag/on request)
Hijssnelheid / Lifting speed	Dubbele snelheid / Double speed
Hijsketting / Load chain	Lastketting volgens EN 818-7 grade DAT / Load chain according to EN 818-7 grade DAT
Stuurkabel / Control cable	Standaard ≈3 meter / Standard ≈3 meter
Stroomkabel / Power cable	≈1 meter zonder stekker / ≈1 meter without plug
Behuizing bescherming / Housing protection	IP 55
Besturing bescherming / Control protection	IP 65
Classificatie / Classification	M5/2m (ISO/FEM)
Inschakelduur / Starts per uur / Duty cycle / Starts per hour	40% / 240
Isolatieklasse / Insulation class	F
Bedrijfstemperatuur / Operating temperature	-20°C - +40°C
Lading type / Load type	Goederen, mag niet gebruikt worden om mensen te hijsen / Goods, may not be used to lift people

Beveiliging / Protection	
Schakelaar / Control switch	24V schakelaar met noodstop / 24V pendant control switch with emergency stop button
Overlastbeveiliging / Overload protection	Extern instelbare slipkoppeling en digitale beveiliging / Externally adjustable slip clutch and digital protection
Rem / Brake	Elektromagnetische veerdrumrem, houdt de lading ook bij stroomuitval stevig vast / Electromagnetic spring pressure brake, holds the load in the event of power failure
Eindschakelaar / Limit switch	Electro-mechanische hoogste en laagste eindschakelaar / Electro-mechanical upper and lower limit switch
Thermische bescherming / Thermal protection	Bescherm door warmtesensor / Protected through heat sensor



Premium Electrische Kettingtakel DEH / Premium Electric Chain Hoist DEH



DF.0.DED



DF.0.DEY

Eigenschappen

- » Elektrische kettingtakel gemonteerd op een (elektrische) loopkat met een lage bouwhoogte.
- » Gebalanceerde steunwielen maken het mogelijk om soepel over de balk te bewegen.
- » Afbreukbeveiligingsbeugels dienen als val-, breek- en stootbeveiliging. Bovendien uitgerust met kantelbeveiliging.
- » Permanent gesmeerde, kogel gelagerde wielen zorgen voor een soepele verplaatsing.
- » Geschikt voor de meeste I- en H-balken.

Features

- » Electric chain hoist mounted on low headroom (electric) trolley.
- » Balance support wheels enable smooth travelling along the beam.
- » Safety bars serve as fall-, breaking- and impact protection. Additionally equipped with tilting protection.
- » Permanently lubricated, ball bearing mounted wheels allow for smooth traversing.
- » Suitable for most I- and H-beam profiles.

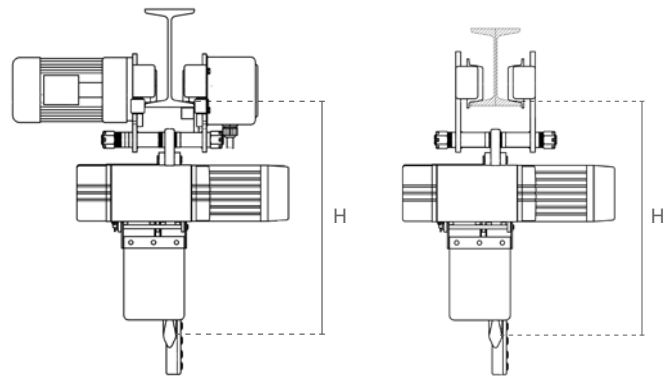

Specificaties / Specifications						
Artikel nummer	Capaciteit	Rijsnelheid	Energie verbruik loopkat	Balkbreedte	Netto gewicht	Min. hoogte (H)
Article code	Capacity	Traversing speed	Power output trolley	Beam width	Net weight	Min. height (H)
	ton	m/min	kW	mm	kg	mm
DF.0.DED.002503	0.25	20/6.7	0.2/0.07	74-300	48	365
DF.0.DED.00503	0.5	20/6.7	0.2/0.07	74-300	59	445
DF.0.DED.01003	1	20/6.7	0.2/0.07	74-300	79	515
DF.0.DED.02003	2	18/6	0.4/0.13	74-300	98	640

Specificaties / Specifications				
Artikel nummer	Capaciteit	Balkbreedte	Netto gewicht	Min. hoogte (H)
Article code	Capacity	Beam width	Net weight	Min. height (H)
	ton	mm	kg	mm
DF.0.DEY.00253	0.25	74-300	40	365
DF.0.DEY.00503	0.5	74-300	51	445
DF.0.DEY.01003	1	74-300	71	515
DF.0.DEY.02003	2	74-300	80	640



Premium Electrische Kettingtakel DEH / Premium Electric Chain Hoist DEH

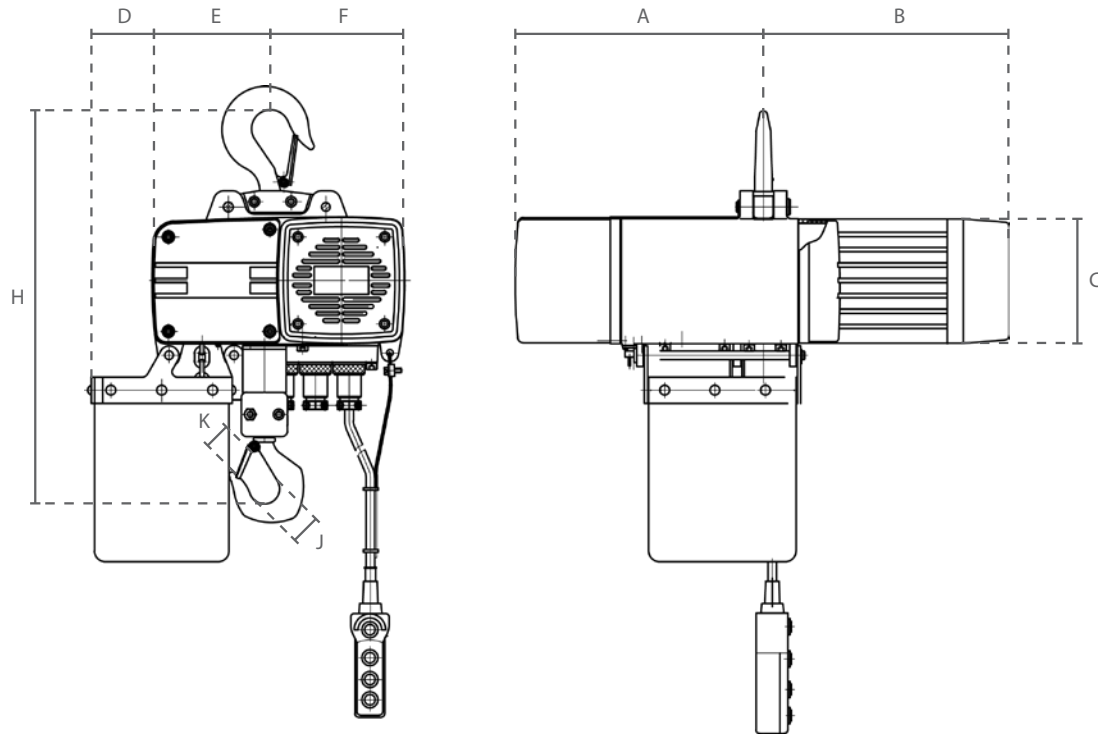

Afmetingen / Dimensions									
Artikel nummer Article code	A	B	C	D	E	F	H	J	K
DF.0.DEH.002503	203	231	115	57	109	124	320	40	26
DF.0.DEH.00503	233	209	165	62	118	162	400	40	26
DF.0.DEH.01003	260	247	175	67	128	187	450	45	32
DF.0.DEH.02003	260	247	175	89	128	187	520	53	38

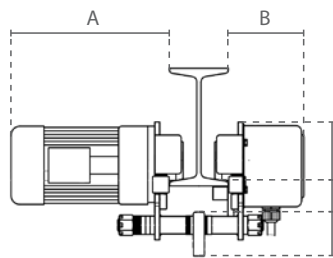
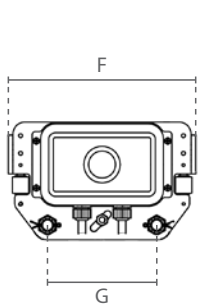

DF.0.DET

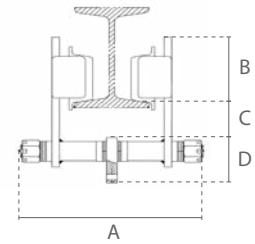
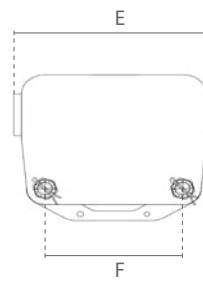

DF.0.026

Specificaties / Specifications					Afmetingen / Dimensions						
Artikel nummer Article code	Capaciteit Capacity	Min. radius Min. radius	Wiel diameter Wheel diameter	Netto gewicht Net weight	A	B	C	D	E	F	G
	ton	m	mm	kg							
DF.0.DET.0252	0.25	1.5	68	26	336	130	99	70	78	340	186
DF.0.DET.0502	0.5	1.5	68	26	336	130	99	70	80	340	186
DF.0.DET.1002	1	1.5	68	26	336	132	99	72	83	340	186
DF.0.DET.2002	2	2	75	40	338	132	122	72	83	340	186
DF.0.02600250	0.25	1.5	75	18	248	112	106	56	270	180	-
DF.0.02600500	0.5	1.5	75	18	248	120	106	56	270	180	-
DF.0.02601000	1	1.5	75	18	248	122	106	56	270	180	-
DF.0.02602000	2	2	75	22	248	122	110	56	270	180	-